

Assembly Layout

主要技术参数 Main Specifications

- 线 数 (Poles) : 02P
- 接触电阻 (Contact resistance) : $\leq 20m\Omega$
- 绝缘电阻 (Insulation resistance) : $\geq 1000M\Omega$
- 额定电压 (Rated voltage) : 150 V AC DC
- 额定电流 (Rated current) : 1.0A AC DC
- 耐电压 (Withstand Voltage) : 1000V AC/minute
- 温度范围 (Temperature Range) : $-25^{\circ}C \sim +105^{\circ}C$

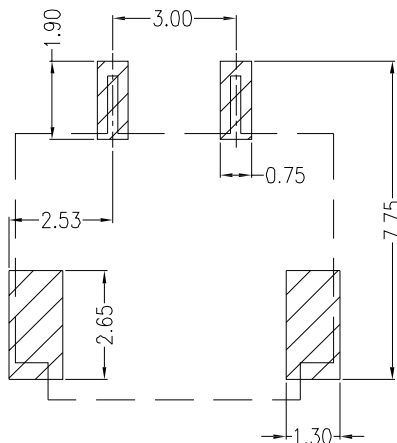
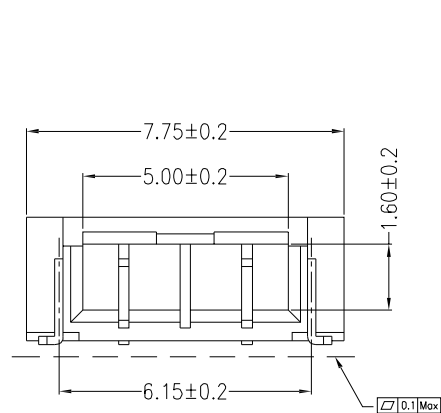

Board Layout
General Tolerance: ± 0.05

NO.	DESCRIPTION	QTY	MATERIAL	PLATING/COLOR
A	Insulator	1	LCP(UL94V-0)	Beige
B	Contacts	2	PhosphorBronze	Tin-plated
C	Solder Tab	2	PhosphorBronze	Tin-plated

UNITS mm	MSTCONN 深圳市德瑞电子有限公司 SHENZHEN DERUI ELECTRONIC CO., LTD.
MAT'L	
FINISH	PART NO.(INTENDED USE) B3. 0-2P-F2MB-R
Q'TY PCS	TITLE: 3. 0-2P卧贴对接插座母座
	APPD:
	CHKD:
	DR: HU 2016. 09. 28
	DWG NO.: B3. 0-2P-F2MB-R
	SCALE 1/1
	SHEET 1/1
	REV. A

X.± 0.3	X°.± 5°
.X± 0.25	.X°.± 2°
.XX± 0.20	.XX°.± 1°
.XXX± 0.10	.XXX°.± 0.5°