

Assembly Layout

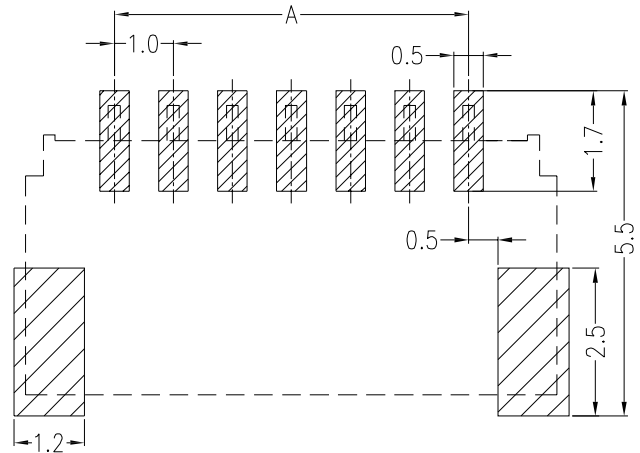
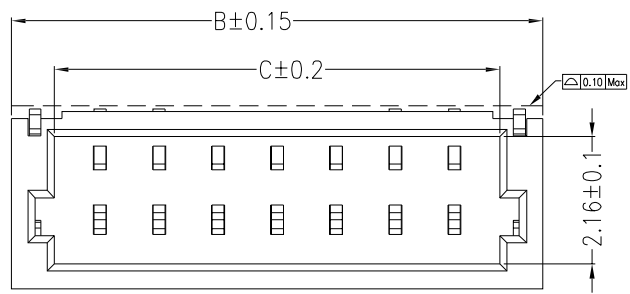

Recommend PCB Layout

主要技术参数 Main Specifications

- 线数 (Poles): 02 to 20
- 接触电阻 (Contact resistance):  $\leq 20m\Omega$
- 绝缘电阻 (Insulation resistance):  $\geq 100M\Omega$
- 额定电压 (Rated voltage): 50V AC DC
- 额定电流 (Rated current): 1.0A AC DC
- 耐电压 (Withstand Voltage): 500V AC/minute
- 温度范围 (Temperature Range):  $-25^{\circ}C \sim +105^{\circ}C$

Circuit	Dimensions (mm)			Circuit	Dimensions (mm)		
	A	B	C		A	B	C
02	1.00	4.00	2.50	10	9.00	12.00	10.50
03	2.00	5.00	3.50	11	10.00	13.00	11.50
04	3.00	6.00	4.50	12	11.00	14.00	12.50
05	4.00	7.00	5.50	13	12.00	15.00	13.50
06	5.00	8.00	6.50	14	13.00	16.00	14.50
07	6.00	9.00	7.50	15	14.00	17.00	15.50
08	7.00	10.00	8.50	16	15.00	18.00	16.50
09	8.00	11.00	9.50	20	19.00	22.00	20.50

NO.	DESCRIPTION	QTY	MATERIAL	PLATING/COLOR
A	Insulator	1	LCP (UL94V-0)	Beige
B	Contacts	2~16	PhosphorBronze	Tin-plated
C	SolderTab	2	PhosphorBronze	Tin-plated

UNITS mm	<b>MSTCONN</b> 深圳市德瑞电子有限公司 SHENZHEN DERUI ELECTRONIC CO., LTD.
MAT'L	
FINISH	PART NO.(INTENDED USE) 1.0-Q-nPWB
Q'TY PCS	TITLE: SH1.0卧贴针座
	APPD: CHKD: DR: HU 2016.09.28
	DWG NO.: 1.0-Q-nPWB
	SCALE: 1/1
	SHEET: 1/1
	REV: A